

EC6000i[®], EC7000i[™], and EC7500i[™] Series Installation Guide





This manual, the EC6000i , EC7000i, and EC7500i Series Installation Guide, is intended for all units belonging to the EC6000i, EC7000i, and EC7500i family of products.

EC6000i is a registered trademark of RDM Corporation. EC7000i, EC7500i, ITMS, RDM, and the RDM logo are all trademarks of RDM Corporation. All other brand names and trademarks appearing in this guide are the property of their respective holders.

Copyright© RDM Corporation, 2009

All rights reserved. No part of this document may be reproduced in any form without the written consent of RDM Corporation.

Part Number: 302665

Revision Number: B

Contents

Compliance Statements	2
Introduction	6
Requirements	7
Setting Up the EC6000i, EC7000i, or EC7500i	8
Operating the Scanner	17
Maintaining the EC6000i, EC7000i, or EC7500i	20
Troubleshooting	22
Specifications	25
Warranty Information	28

Compliance Statements

FCC Compliance Statement

NOTE for EC6000i and EC7000i Series Scanners: This equipment has been tested and found to comply with the limits for a Class A digital device, pursuant to part 15 of the FCC Rules. These limits are designed to provide reasonable protection against harmful interference when the equipment is operated in a commercial environment. This equipment generates, uses, and can radiate radio frequency energy and, if not installed and used in accordance with the instruction manual, may cause harmful interference to radio communications. Operation of this equipment in a residential area is likely to cause harmful interference in which case the user will be required to correct the interference at his/her own expense.

NOTE for EC7500i Series Scanners: This equipment has been tested and found to comply with the limits for a Class B digital device, pursuant to Part 15 of the FCC Rules. These limits are designed to provide reasonable protection against harmful interference in a residential installation. This equipment generates, uses, and can radiate radio frequency energy and, if not installed and used in accordance with the instruction manual, may cause harmful interference to radio communications. However, there is no guarantee that interference will not occur in a particular installation. If this equipment does cause harmful interference to radio or television reception, which can be determined by turning the equipment off and on, the user is encouraged to try to correct the interference by one or more of the following measures:

- Reorient or relocate the receiving antenna.
- Increase the separation between the equipment and receiver.
- Connect the equipment into an outlet on a circuit different from that to which the receiver is connected.
- Consult the dealer or an experienced radio/TV technician for help.

Models with internal modem: Modem-equipped models comply with Part 68 of the FCC rules and the requirements adopted by the ACTA. They connect to the telephone line by means of a standard jack (USOC RJ-11C). On the bottom of the equipment is a label that contains, among other information, the product identifier US: RCOMM00B2433RDM3, with no explicit mention of Ringer Equivalence. If requested, this information must be provided to the telephone company.

The Ringer Equivalence Number (REN) is used to determine the number of devices that may be connected to a telephone line. Excessive RENs on a telephone line may result in the devices not ringing in response to an incoming call. In most, but not all areas, the sum of RENs should not exceed five (5.0). To be certain of the number of devices that may be connected to a line, as determined by the total RENs permissible on your

telephone line, contact the local telephone company. The REN for the EC6000i, EC7000i, or EC7500i Series Scanner is found on the underside of the unit. The digits 00 are the REN without a decimal point (00 is the REN of 0.0).

The plug and jack used to connect this equipment to the premises wiring and telephone network must comply with the applicable FCC Part 68 rules and requirements adopted by the ACTA. A compliant telephone cord with modular plug is provided with this product. It is designed to connect to a compatible modular jack that is also compliant. See the installation instructions for details.

If this equipment is equipped with a modem and causes harm to the telephone network, the telephone company will notify you in advance that temporary discontinuance of service may be required. If advance notice is not feasible, you will be notified as soon as possible. When you are notified, you will be given the opportunity to correct the problem and informed of your right to file a complaint with the FCC if you believe that it is necessary. Contact your telephone company if you have any questions about your phone line.

Telephone Company Procedures: The goal of the telephone company is to provide you with the best service it can. In order to do this, it may occasionally be necessary for them to make changes in their equipment, operations or procedures. If these changes might affect your services or the operation of your equipment, the telephone company will give you notice, in writing, to allow you to make any changes necessary to maintain uninterrupted service. Connection to party line service is subject to state tariffs. Contact the state public utility commission, public service commission, or corporation commission for information. Connection to Telephone Company provided coin service is prohibited.

If the building where a modem-equipped RDM product is installed has specially wired alarm equipment connected to the telephone line, ensure that the installation or operation of the modem does not disable your alarm equipment. If you have questions about what will disable alarm equipment, consult your telephone company or a qualified installer.

CAUTION: Changes or modifications not expressly approved by RDM Corporation could void the user's authority to operate the equipment.

All units covered by this manual have no user-serviceable parts inside. In the event repairs are ever needed to any RDM product, they should be performed by RDM Corporation or an authorized representative of RDM Corporation. For information please contact RDM Corporation, 4-608 Weber Street North, Waterloo, Ontario, Canada N2V 1K4, at 1-800-567-6227, or RDM's US service agent below.

US Service Agent

Jason S. Miller

(812) 285-1966

jmiller@rdmcorp.com

Industry Canada Compliance Statement

This product meets the applicable Industry Canada technical specifications/Le présent matériel est conforme aux spécifications techniques applicables d'Industrie Canada.

The Ringer Equivalence Number is an indication of the maximum number of devices allowed to be connected to a telephone interface. The termination on an interface may consist of any combination of devices subject only to the requirement that the sum of the RENs of all the devices does not exceed five/L'indice d'équivalence de la sonnerie (IES) sert à indiquer le nombre maximal de terminaux qui peuvent être raccordés à une interface téléphonique. La terminaison d'une interface peut consister en une combinaison quelconque de dispositifs, à la seule condition que la somme d'indices d'équivalence de la sonnerie de tous les dispositifs n'excède pas 5.

For information contact: RDM Corporation, 4-608 Weber Street North, Waterloo, Ontario, Canada N2V 1K4

Introduction

The EC6000i[®], the EC7000i[™], and the EC7500i[™] Series Scanners are cost effective, feature rich, imaging solutions. Using RDM's industry leading progressive MICR method and imaging technology, the EC6000i, the EC7000i, and the EC7500i Series Scanners are ideal for Check Electronification, Check Cashing, and Walk-in Bill Payment applications.

Requirements

- The EC6000i, the EC7000i, and the EC7500i units are for indoor use only. Keep the EC6000i, the EC7000i, and the EC7500i **dry**; avoid areas of high humidity.
- **Do not remove any cabinetry** other than the areas specified in this guide. Removing cabinetry other than the areas specified in this guide will void the warranty.

Recommendations

- This unit may be installed and programmed by a distributor (reseller) other than the original manufacturer. Record all distributor contact information for future reference.
- **Save the original box** and packing material. Reuse them if the unit must be shipped to a new location.
- **Position the unit** so that the operator has easy access to the check path and a clear view of the LED. Do not put the unit close to a heat source, in direct sunlight, or close to any device that can emit electromagnetic interference, such as a computer monitor or power adapter.

Setting Up the EC6000i, EC7000i, or EC7500i

To set up the EC6000i, the EC7000i, and the EC7500i, follow steps A – H.

A. Choose a Location

Locate your scanner in a place that:

- has a flat surface, such as a countertop or table
- is convenient for the scanner operator
- offers adequate ventilation and protection from elements such as heat, dust, oil, or moisture
- is close to a telephone line or network connection (depending on your unit) and power connections.

B. Unpack the Shipping Box

1. Open the top of the box.
2. Remove and unwrap the items.
3. Save the box and wrapping for future use.

NOTE: Before unpacking the box, examine it for damage received during shipping. If the scanner, or any component, appears damaged, do not use it. File a claim with the shipping company and contact your distributor.

Your EC6000i, EC7000i, or EC7500i product package includes the following:

- The EC6000i, the EC7000i, or the EC7500i scanner
- Power adapter
- Telephone line (optional with modem) - EC6000i or EC7000i only
- Franking Acknowledgement Printer Cartridge (optional) - Reorder P/N 6000-6050
- USB cable

C. Inspect the Unit's Features

The illustrations below show a basic scanner (Model A), and an EC7500i scanner with a Magnetic Stripe Reader (MSR) and printer (Model B). Scanner Model A will be graphically represented throughout this manual for consistency. All other features of the EC6000i, the EC7000i, and the EC7500i are available as standard or optional. All EC7500i series models are franker-enabled. Specific EC6000i and EC7000i series models have franking capability.

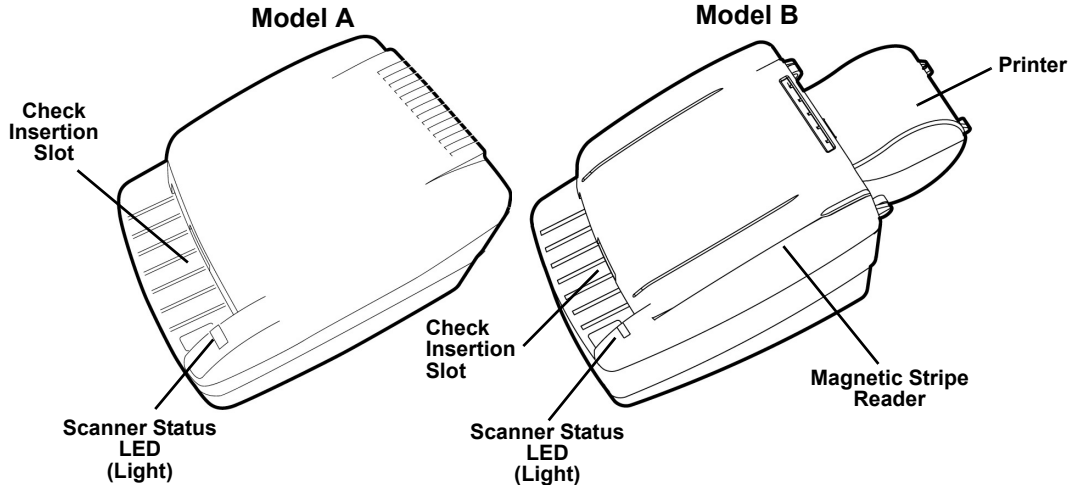

Inside Components

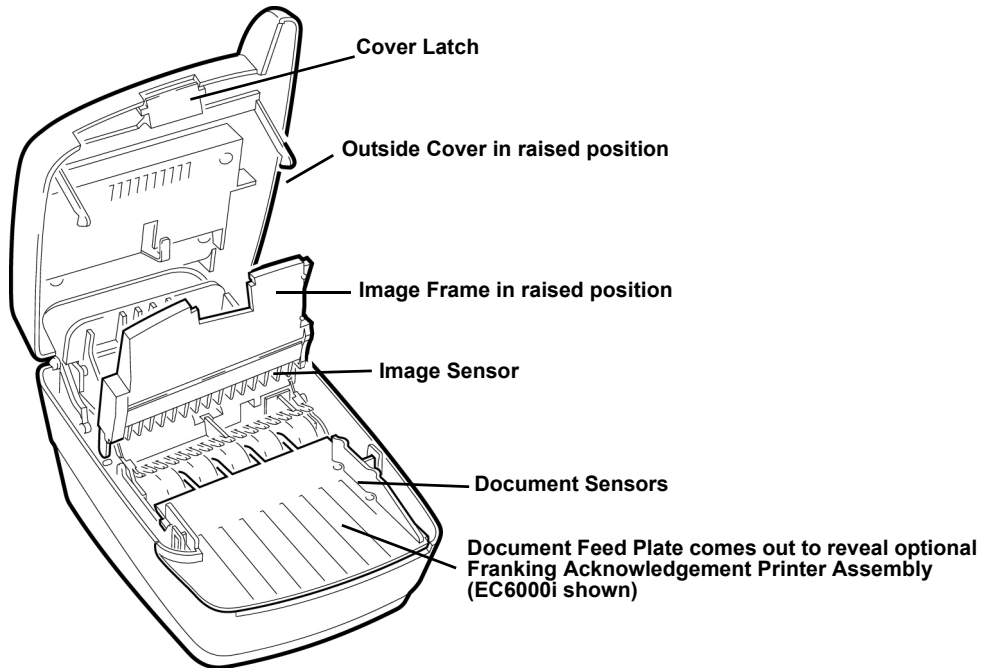

Connection Ports

RDM's EC6000i, the EC7000i, and EC7500i can be installed in different configurations. These configurations are set and programmed by the distributor (reseller) to suit your unique needs.

Follow instructions provided by your distributor (reseller).

- Power:** Red. Connect the power adaptor to this port.
- USB:** Orange. Use this port to connect to a PC.
- AUX:** Yellow. Use this port to connect optional peripheral devices such as a pass through printer. (EC6000i, the EC7000i only)
- COM:** Green. Use this port to connect to a PC or terminal (EC6000i, the EC7000i only).
- TEL:** Purple. This port offers an optional modem to be connected to a telephone line. Some scanners may not contain a TEL Port (EC6000i, the EC7000i only).

EC6000i and EC7000i Connectors

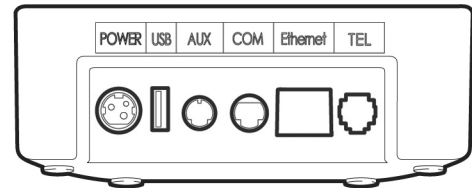

EC7500i Connectors

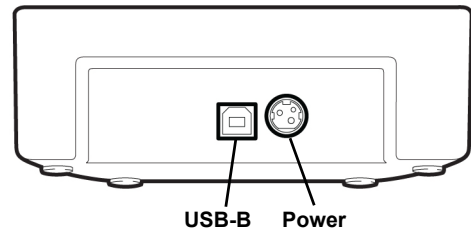

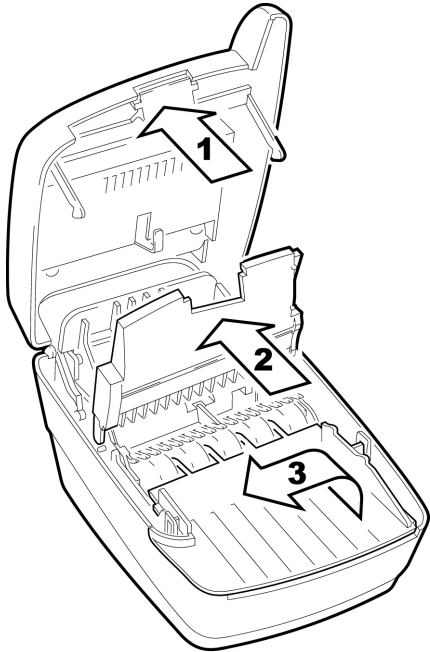

D. Insert the Franking Acknowledgement Printer Cartridge (Optional)

The Franking Acknowledgement Printer Cartridge is an optional ink stamp, that marks the front of each check with a “Electronically Presented” message, or a message that you create. If you have purchased this option, follow these directions to insert the printer cartridge into the unit.

I. Access the Printer Assembly

1. Press the latch and lift the cover to access the imaging frame.
2. Lift the imaging frame to access the feed plate.
3. Locate the blue tab on the side of the unit.
 - a. With your thumb on the outside of the unit, apply enough pressure to pull the blue tab towards the outside of the unit and hold it there.
 - b. While holding the blue tab, lift the document feed plate up and to the left or up and to the right to free it from the opposite side.
 - c. Remove the plate completely. (continued...)

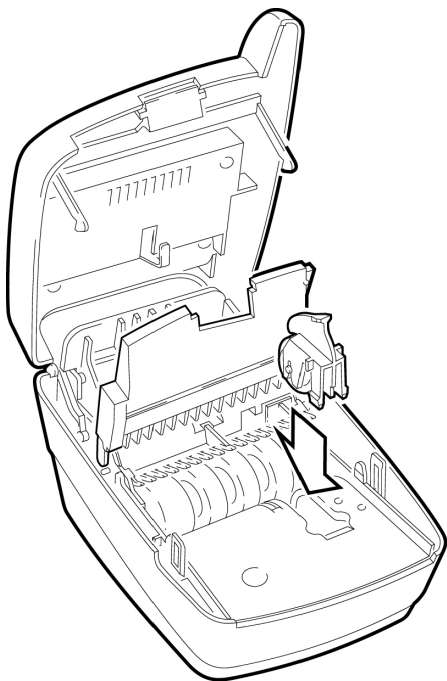

II. Insert the Franking Acknowledgement Printer Cartridge into the Printer Assembly

1. Insert the Franking Acknowledgement Printer Cartridge straight into the printer assembly.
2. Apply pressure to the widest part of the flat top until the cartridge clicks into place.
3. Replace the document feed plate by pressing down firmly until it clicks into place.
4. Close the imaging frame.
5. Close the outside cover.

CAUTION:

- Avoid contact with the main drive roller to prevent ink transfer to documents.
- Ink may be harmful if swallowed.
- Avoid contact with eyes.
- Damage to the unit or the cartridge resulting from modifying the cartridge is not the responsibility of RDM.
- The ink cartridge is not refillable.
- Not licensed for modifications.

E. Connect to a Telephone Line (EC6014 and EC7014)

FOR TEL: If you have purchased the EC6000i or the EC7000i with the optional modem, follow these directions to connect the telephone line.

1. Insert the end of the telephone line into the **TEL** port on the back of the scanner.
2. Insert the other end of the telephone line into a telephone jack in the wall.

CAUTION: Plug the telephone line into an “outside line” analog phone jack only; the modem will not work if it is plugged into a PBX digital line.

Test the Telephone Line and Third-Party Line

1. Call the third-party line to ensure that it is working properly.
2. If the third-party line is not working, contact your local telephone company for repair.
3. If the telephone line works, contact your distributor to have the EC6000i or the EC7000i serviced.

F. Connect the Power Cord

1. Insert the round end of the power cord into the power port on the back of the scanner.
2. Align the flat side of the power connector facing up.
3. Plug the metal-pronged end of the power cord into an electrical power outlet.
4. When you connect to power, the LED lights up. Your unit is now powered on.

CAUTION: Disconnecting the power source while the terminal is processing a transaction may cause data files stored in the unit's memory to be lost.

NOTE: The power adaptor includes a locking mechanism that securely connects the power cord to the scanner. To prevent cord damage, do not pull on the cord. Firmly slide back the locking mechanism before disconnecting the power cord from the unit.

G. Drivers

The drivers for your scanner are installed when you install your PC application. If it is a Web-based application, ActiveX may be installed. There are many applications that support RDM EC Series Scanners; most are available from third-party vendors.

If you are not sure where to acquire your PC application, check with the reseller from whom you purchased your scanner, your bank, or your service provider.

H. Install the Printer Paper Roll

EC Series Scanners that include a printer use single-ply, thermal-sensitive paper that comes in a roll that is 2.25 inches (5.8 cm) wide.

CAUTION: Handle thermal paper with care; friction, humidity, light, etc, will damage it. Do not load paper with wrinkles, folds, or tears. For best results, cut the paper, rather than tearing it, to feed it into the printer.

To install a roll of paper:

1. Ensure that scanner is powered on.
2. Swing open the clear plastic paper roll cover at the back of the unit.
3. Hold the paper roll with the paper feeding from the bottom and guide the straight-cut end of the paper into the paper feed slot that is in line with the holder. The feed mechanism will start to pull the paper into the unit.
4. Place the roll loosely into the paper roll holder.
5. Swing the paper roll cover back into place.

Operating the Scanner

Preparing Checks

To reduce the possibility of errors and damage to the unit, you should:

- Remove all folds and creases in the check.
- Remove any paper clips and staples from the check.



Feeding Checks

The scanner unit is ready to accept checks when the LED is green. Insert the check in the following way:

- Flush to the right side of the scanner.
- Information-side facing up.
- MICR line to the inside right.

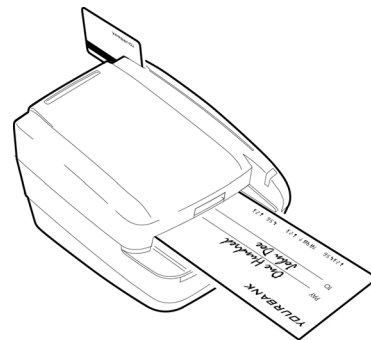

Swiping Magnetic Stripe Cards (Optional)

Swipe the credit card with the black, magnetic stripe facing downward, and to the left.

CAUTION: Do not open the cover or otherwise try to access the inside of the unit while it is in the process of scanning a document.

Understanding Status Signals

The scanner comes equipped with the default light and sound signals described below.

Default Light Signals

The unit's status is shown through a single, multi-state LED (light-emitting diode), which is the light on the top, front, right-hand side of the unit. The table below describes typical status signals and their meanings.

LED	Meaning; What To Do
Green Solid	The unit is ready to accept a check; insert a check.
Green Flashing	The unit is busy, processing the last check; wait for the job to finish.
Amber Solid	The unit is idle ; start the next job with a command from the terminal or PC application.
Amber Flashing	The unit is sending or receiving information from the terminal or PC application; wait.
Red / Green / Amber Flashing	The unit is starting up or performing diagnostics ; wait.
Red Solid	The unit failed during a self-test; check the terminal display for instructions / refer to your local procedures / call you distributor (reseller).
Red Flashing	An error occurred during processing. See "Default Sound Signals" on the next page for details; check the terminal display for instructions / refer to your local procedures / call your distributor (reseller).

Default Sound Signals

Several conditions are also signaled by a pattern of tones in addition to the LED display.

Tone	Meaning
One short beep LED is flashing green	The unit was successful in reading the MICR line.
Three short beeps LED is flashing red	The unit was not successful in reading the MICR line.
One long beep LED is flashing red	An error occurred during processing or storing of the captured image.

A Typical Check Processing / LED Cycle

1. The LED is **Solid Amber**; the unit is on and idle.
2. The LED turns to **Solid Green**; the scanner is ready to accept a check.
3. The LED turns **OFF** (3–4 seconds), and then **Flashes Green**; a check is being scanned. The unit emits a short beep sound.
4. The LED returns to **Solid Amber**; the transaction is complete.

Maintaining the EC6000i, EC7000i, or EC7500i

The EC6000i, EC7000i, or EC7500i performs best when all working surfaces are clean and free of foreign material.

Cleaning the Scanner

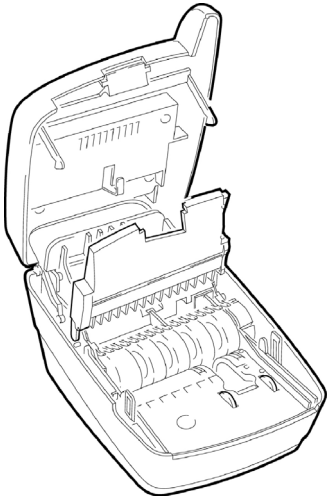

CAUTION:

- Always disconnect the power to the scanner before cleaning it.
- Solvents or harsh cleaners may damage or discolor the cabinetry.

- **To clean the outside cabinetry:** Use a damp cloth and mild soap.
- **To clean the inside of the unit:**
 1. Press the latch and lift the cover to access the imaging frame.
 2. Lift the imaging frame to access the document feed plate.
 3. Locate the blue tab on the side of the unit. With your thumb positioned on the outside of the unit, apply enough pressure to pull the blue tab towards the outside of the unit and hold it there.
 4. While holding the blue tab, lift the document feed plate up and to the left or up and from the right to free it from the opposite side.
 5. Remove the plate.
 6. Ensure that the black fingers on the baffle move freely (EC7000i only).
 7. Use a dusting brush designed for use on electronic equipment, or use a compressed air duster to remove dust or debris.

Cleaning the Imager

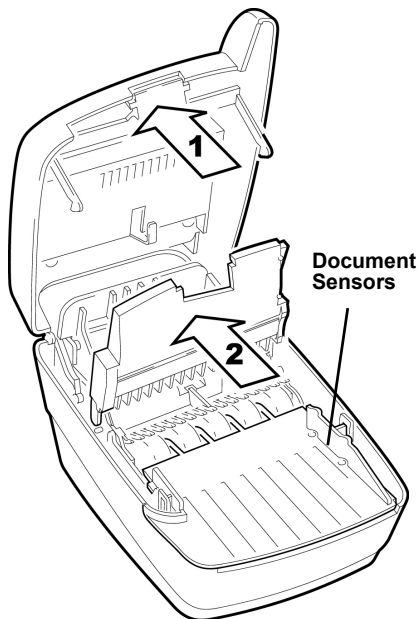

Occasionally, it may be necessary to clean the image sensors and remove dust or debris from the interior of the EC6000i, the EC7000i, or the EC7500i.

To locate and access the document sensors:

1. Press the latch and lift the cover to access the imaging frame.
2. Lift imaging frame to access the document sensors.
3. Use a lens-cleaning tissue or a damp, lint-free cloth to remove any ink or dust from the document sensors or the main drive roller.

Troubleshooting

In the course of everyday operations, you may encounter minor malfunctions in the EC6000i, the EC7000i, or the EC7500i unit. Before calling for service, review the troubleshooting steps below.

Modem Does Not Function (EC6000i and EC7000i only)

1. Examine the telephone cord and all telephone connections to ensure that they are still connected properly.
2. Ensure the telephone line is working by removing the connection from the EC6000i or the EC7000i and connecting it to a telephone base unit.
3. If the telephone line is not working, contact your local telephone company for repair.

Peripheral Device Does Not Respond

1. Ensure that the scanner's cable is still properly connected to the correct port on the back of the unit (according to instructions provided by your distributor).
2. If the problem persists, contact your distributor.
3. Ensure that the correct power adaptor is connected to the unit. Change the adaptor, if necessary.

Check Feeder Does Not Function Properly

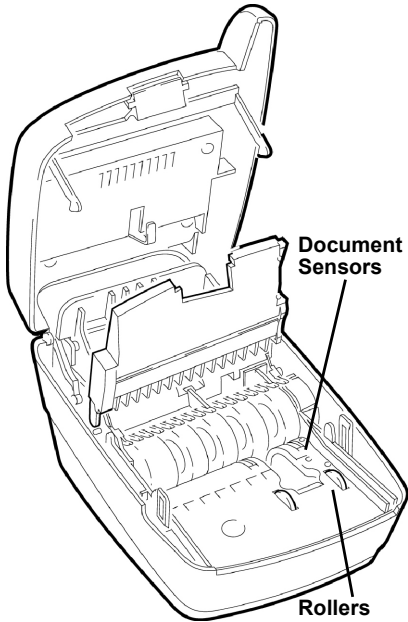

Ensure that you are inserting the check properly: flush to the right side of the EC6000i, the EC7000i, or the EC7500i, information-side facing up, with the MICR line to the inside right. If the problem persists, contact your distributor. Remove any debris by following the directions below:

1. Press the latch and lift the cover to access the imaging frame.
2. Lift the imaging frame to access the document feed plate.
3. Clear any paper or debris from the imaging frame and document feed plate.
4. Ensure that the black fingers on the baffle move freely (EC7000i and EC7500i only).
5. Use a lens-cleaning tissue or a damp, lint-free cloth to remove any ink or dust from the document sensors.
6. Ensure that the rollers under the baffle are clean.
7. Close the imaging frame and cover.

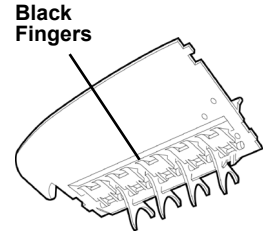

Card Transactions Do Not Function Properly

Test the Card Swipe Mechanism

1. Ensure that you are swiping the card properly. The black magnetic stripe on the back of the card must face downward and to the left.
2. Try using another card to ensure the first card was not defective.

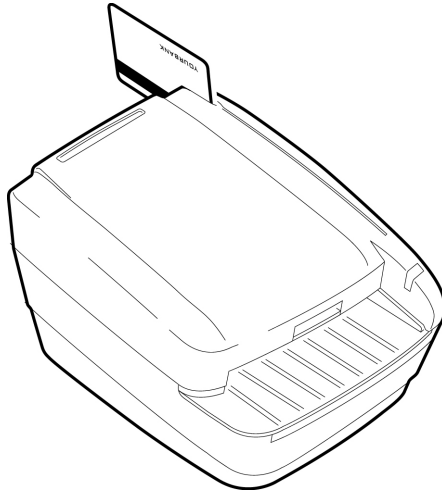

Specifications

EC6000i, EC7000i, EC7500i Specifications	
Unit Size	Without MSR 8.6" long x 6.1" wide x 4.4" high 21.9 cm long X 15.4 cm wide X 11.3 cm high With MSR 8.6" long x 6.1" wide x 5.3" high 21.9 cm long x 15.4 cm wide x 13.5 cm high With Printer 11.8" long x 6.1" wide x 5.3" high 30.1 cm long x 15.4 cm wide x 13.5 cm high
Unit Weight	EC6000i: 3.1 lbs. / 1.4 Kg EC7000i: 3.4 lbs. / 1.5 Kg EC7504i with printer: 6.0 lbs / 2.7 Kg with power supply
Unit Orientation	For proper operation, place unit on a level, horizontal surface.
EC6000i and EC7000i Connectors	Power: Red. Mini-DIN 3-pin. USB: Orange. USB-A. (1.1) AUX: Yellow. Mini-DIN 8-pin. COM: Green. Mini-DIN 9-pin. TEL: Purple. RJ11 plug. Modem (optional).
EC7500i Connectors	Power: Mini-DIN 3-pin USB: USB-B (2.0)

Environmental	
Operating Temperature	32 to 104 degrees F (0 to 40 degrees C).
Operating Humidity	10 to 85% relative humidity (non-condensing).
Document Specifications	
Document Size and Weight	Nominal: 2.16" W x 4.4" L (5.5 cm x 11.2 cm) Maximum: 4" W x 9" L (10.16 cm x 22.86 cm) Weight Range: 8 lb to 100 lb (thermal paper to business card stock) Preferred Range: 16 lb to 32 lb
Fonts	E13B MICR Character Set CMC7 MICR Character Set Alphanumeric OCR A and B font recognition (optional)
Electrical Power Requirements for Power Adapter	
	Use an RDM-supplied power adaptor.
Power Supply (RDM P/N # 302843)	Input: 100–240 V AC, 50–60Hz Output: 24V, DC 1.0A

(Optional) Modem Specifications	
Supports	V.34bis, V.34 V.F.C, V.32bis, V.32, V.22bis, V.22A/B, V.23, V.21, Bell 212A and 103
Error Correction	V.42 LAPM and MNP 2-4
	V.42bis and MNP 5
(Optional) Magnetic Stripe Reader (MSR) Specifications	
	3 track, bi-directional

Consumables	
Printer Roll	Thermal, 2.25" x 50' (58 mm x 15 m) Reorder P/N #302562
Franking Acknowledgement Printer Cartridge	Reorder P/N #6000-6050

Warranty Information

LIMITED WARRANTY:

The RDM EC6000i units are warranted against defects in materials and workmanship under normal use and service for a period of one year after the date of receipt by you. The RDM EC7000i and EC7500i units are warranted against defects in materials and workmanship under normal use and service for a period of two years. This warranty is extended only to the original purchaser.

The entire liability of RDM Corporation (the Corporation), distributors of the EC6000i, EC7000i, and EC7500i and manufacturers of auxiliary equipment used with the EC7000i and EC7500i and your exclusive remedy shall be, at the Corporation's option either (a) return of the price paid, or (b) repair or replacement of the EC7000i and EC7500i that does not meet this limited warranty and which is returned to the Corporation with a purchase receipt or other proof of date of original purchase which will be required in order to exercise your rights under this warranty.

The limited warranty is void if failure of the EC6000i, EC7000i, or EC7500i has resulted from accident, abuse or misapplication. Any replacement of the EC6000i, EC7000i, or EC7500i will be warranted for the remainder of the original warranty period.

The equipment is sold with the understanding that neither the Corporation, such distributors nor such manufacturers will be liable for any damages whatsoever (including, without limitation, direct or indirect damages for personal injury, loss of business profits, business interruption, loss of business information, or any other pecuniary loss) arising out of the use of or inability to use the EC6000i, EC7000i, or EC7500i, even if the Corporation, such distributors and/or such manufacturers have been advised of the possibility of such damages.

In any case, the entire liability of the Corporation, such distributors and such manufacturers with respect to the EC6000i, the EC7000i, or the EC7500i shall be limited to the amount actually paid by you for the EC6000i, the EC7000i, or the EC7500i.

The Corporation, such distributors and such manufacturers disclaim all other warranties, express or implied, including, without limitation, implied warranties of merchantability and fitness for a particular purpose with regard to the EC6000i, the EC7000i, or the EC7500i and the accompanying written materials.

Although every effort has been made to ensure the accuracy of the information contained in this guide, no warranty or representation to that effect is made. Due to product improvements, specifications are subject to change without notice.

WARRANTY SPECIFICS:

This warranty only covers failures due to defects in materials or workmanship, which occur during normal use. It does not cover the following:

- Damage, which occurs in shipment,
- Failures which are caused by products not supplied by RDM or failures which result from accident, misuse, abuse, neglect, excessive dirt or dust caused by lack of preventive maintenance measures, mishandling, misapplication, alteration or modification; service by anyone other than RDM, or damage that is attributable to acts of nature including but not limited to:
 - Flood, lightning, power surges or static electricity, water damage, falls, theft, or vandalism,
 - Spillage of liquid or objects that have fallen into the equipment,
 - Equipment that has been exposed to excessive heat or unstable environmental conditions,
 - Consumables such as Franking Acknowledgement Printer Cartridge or Franker Assembly, or other EC6000i, the EC7000i, or the EC7500i consumables or accessories such as cables.

RDM's EC6000i, the EC7000i, or the EC7500i units with problems found to be caused by incorrectly set configuration parameters (IRN #, Owner Code, Merchant ID, etc.) are not considered defective and will not be serviced under warranty.

Warranty is void if any of the external case of the unit has been opened or removed or the unit has, in RDM's opinion, been damaged through misuse or improper care.

Units returned to RDM for warranty repair will be re-configured with factory defaults and returned to customers. All stored images in the scanner will be cleared. Customers will have the option of having the images uploaded to RDM's Image & Transaction Management System (ITMS™) for archiving or e-mailed to them prior to being cleared from the scanner.



Copyright© RDM Corporation, 2009

All rights reserved. No part of this document may be reproduced in any form without the written consent of RDM Corporation.

Part Number: 302665
Revision Number: B

Waterloo, Ontario
Canada



Printed on 100% Recyclable Paper

